

FDC600Y

Intelligent Field Communication Box

Brief Views

The intelligent field communication box is designed for use in open-air outdoor environments, offering all-weather outdoor electrical protection.

By installing various business modules, it enables the convergence and transmission of multiple services. The shell is made from high-quality cold-rolled steel plate (with options for galvanized or stainless steel), providing rainproof, dustproof, ventilated, heat-dissipating, and corrosion resistance properties. The pole-mount structure design is convenient for quick installation.

The built-in environmental parameter acquisition control module adjusts the internal fan to dissipate heat based on the temperature inside the box. The control module also triggers an audible alarm when the box door is illegally opened. A water sensor can detect the water level inside the box and issuing an alarm, while a smoke sensor can detect the smoke level inside the box and triggers an alarm if needed.

An optional 4G+GPS module allows for location tracking, with alarms sent via the web if the box is illegally moved. The power redundancy backup design ensures the long-term reliability of the equipment. With an optional battery power supply, the system will automatically switch to battery power if mains power fails.

The intelligent field communication box is equipped with web and CMS management functionality for easy monitoring and control.



Closed View



2pcs OLT module and
1pcs EYDFA module installed

1. Product Specification

1.1 OLT module specification

Refer to the OLT module FD1608Y-B0M datasheet

1.2 EYDFA module specification

Refer to the EYDFA module HF1915Y-C1M-1623W datasheet

1.3 Environmental parameter acquisition control module specifications

Name	Parameter
Fan start temperature	45 °C
Heater start temperature	-5 °C

Lights status and Results

Name	Light ON	Light Flashing	Light OFF	Notes
SYS	System working normal	/	System is unnormaled	Green light
WIFI	WIFI function open	Data transmitter	WIFI function off	Green light
ETH	ETH connect normal	Data transmitter	EHT unconnected	Green light
Battery Low	Battery over discharge protection	/	Battery voltage is normal	Green light
CHARGING	Battery is charging	/	Battery is not charging	Green light
CHARGED	Battery is fully charged	/	Battery is not fully charged	Green light
14.4V Charging	14.4V charge mode is selected	/	14.4V charge mode is unselected	Green light
12.6V Charging	12.6V charge mode is selected	/	12.6V charge mode is unselected	Green light
FAN1	Fan1 is working	/	Fan1 is unworking	Green light
FAN2	Fan2 is working	/	Fan2 is unworking	Green light
POWER	RTU-100 module power on	/	RTU-100 module power off	Green light
ALARM	With alarms	/	Without alarms	Red light

1.4 Operating Specifications of Intelligent Field Communication Box

Name	MIN	Typ.	MAX	Unit
Store temperature	-40		85	°C
Storage humidity	5		95	%
Operate temperature (with heater)	-25		65	°C
Operate temperature (no heater)	0		65	°C
Work humidity (non-condensing)	10		90	%
Power consumption (no heater)	N/A		120	W
AC input voltage	100	220V	240	V

2. Product hardware design specification

2.1 Hardware principle block diagram

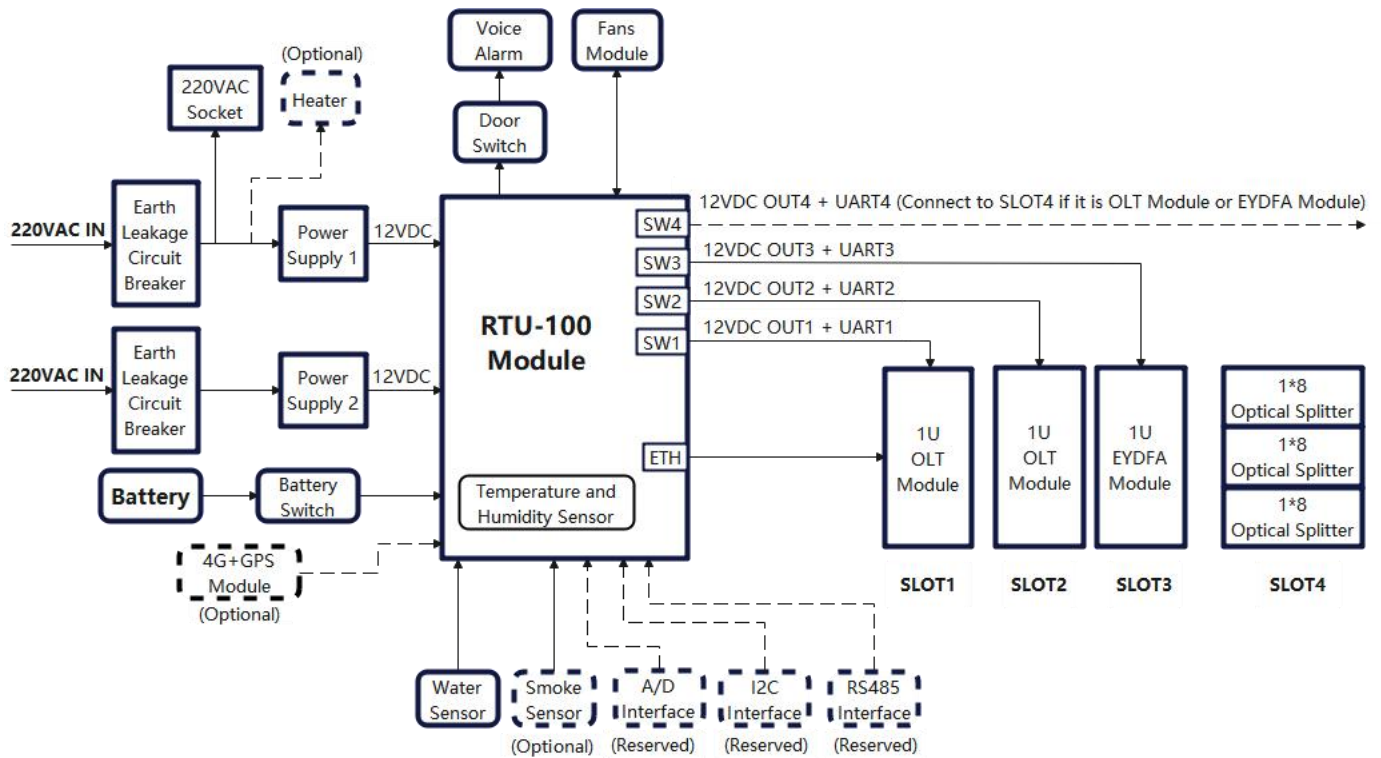

This intelligent field communication box is mainly composed of the following modules:

OLT module, EYDFA module, power supply module, cabinet environment collection and control module (RTU-100 Module), among which the cabinet environment collection and control module includes power redundancy backup, power-off battery life control, environment collection control, etc.

2.2 Principle block diagram of battery charging, switching, and over discharge protection

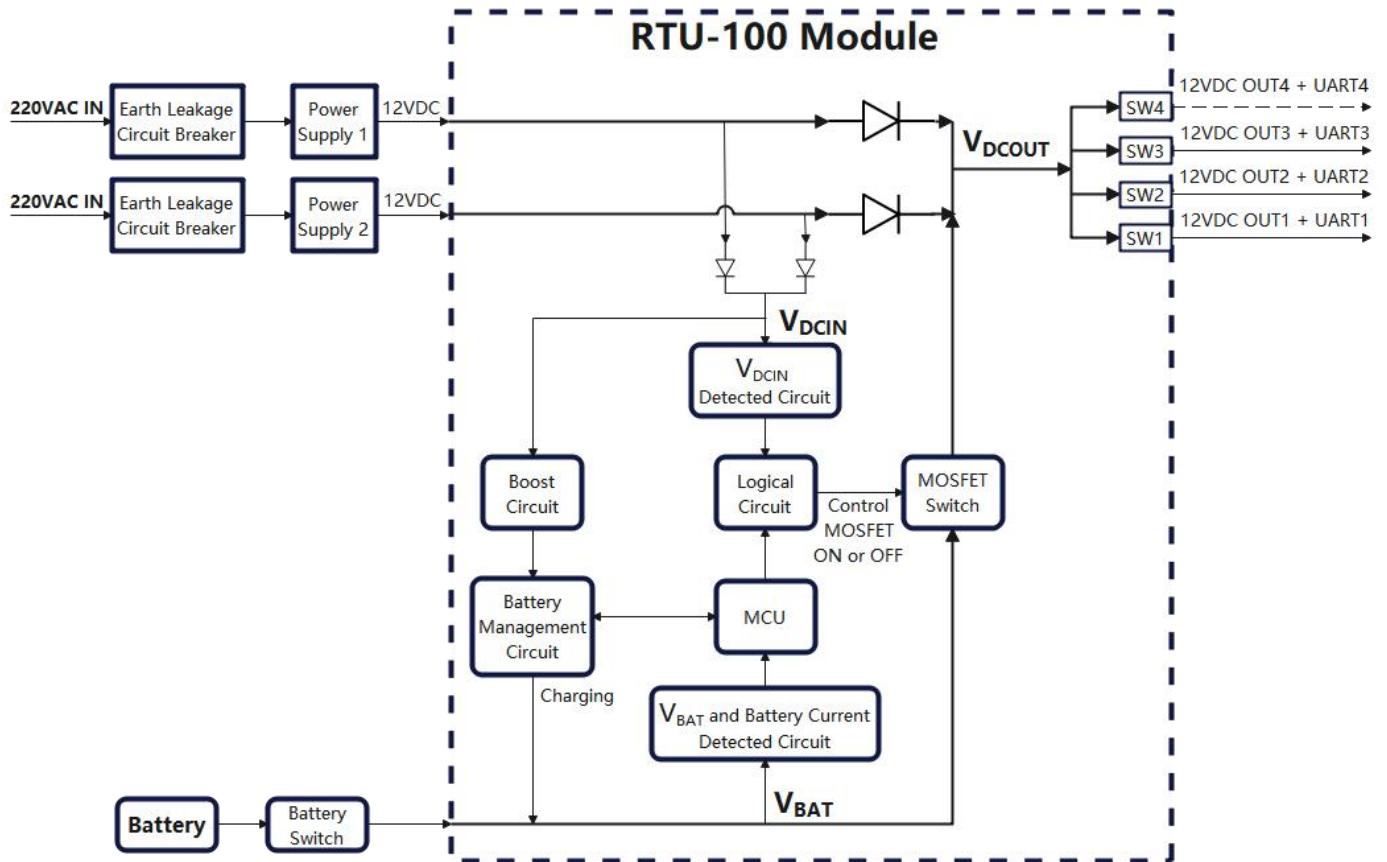

2.2.1 Battery charging:

When 220VAC mains power is connected, the **Logical Circuit** controls the **MOSFET** to turn **OFF**, and the battery is in charging mode. The V_{DCOUT} is provided by **Power Supply1** and **Power Supply2**.

2.2.2 Battery switching:

When 220VAC mains power is not connected, the **Logical Circuit** controls the **MOSFET** to turn **ON**, and the battery is in discharge mode. The V_{DCOUT} is provided by **Battery**.

2.2.3 Battery over discharge protection:

When 220VAC mains power is not connected, the **Logical Circuit** controls the **MOSFET** to turn **ON**, and the battery is in discharge mode. And when the battery voltage is below the over discharge protection threshold, the **MCU** will send a signal to the **Logical Circuit** to forcibly turn **OFF** the **MOSFET**. The V_{DCOUT} is equal to zero.

2.3 Main configuration of intelligent field communication box

Name	Quantity	Remark
OLT module	Max 2 (with EYDFA module)	Individually packaged
	Max 3(without EYDFA module)	
	Max 4(without EYDFA module and Optical Splitter module)	
EYDFA module	Max 1	Individually packaged
Optical Splitter Module	Max 3	One 1*8 port module is configured by default
Earth Leakage Circuit Breaker	2	
Switching power supply	2	
220VAC Socket	1	
Control Module	1	RTU-100 Module
Fan	2	
Water Sensor	1	
Smoke Sensor	1	Optional
Battery (28AH)	1	Optional
4G+GPS Module	1	Optional
Heater (45W)	1	Optional

Mechanics

Bare metal Dimensions (length*width*height)	580*350*530mm	OLT module and EYDFA module are not installed
Bare metal weight	20 Kg	
Packing Dimensions (length*width*height)	760*655*535 mm	
Packed weight	36 Kg	

Copyright © Shenzhen C-Data Technology Co., Ltd. 2024. All rights reserved.

Without the prior written consent of C-DATA, any reproduction, excerpting, backup, modification, translation or any other form of commercial use of this document or any portion of this document, and in any form or by any means, to transmit the document are prohibited.